

SHADE HEAVY

Can thicker be better? For the SHADE HEAVY it certainly is. The screen is wider than standard types, making it easier to absorb unwanted sounds such as colleagues talking or noise from the printer. Just place the screens around the office as needed and let peace and quiet prevail.





TECHNICAL DETAILS

basic dimensions (w x h)	800 x 1800 mm / 31.5 x 70.9 in 1200 x 1800 mm / 47.2 x 70.9 in
material	support plate covered on both sides with special sound-absorbing material
surface finish	decorative fabric (refer to swatches)
feet	solid oak wood
acoustic properties	$\alpha_w^* = 1,00$ – class A – very high absorptive (weighted coefficient of sound absorption)

* measured in compliance with ISO 354, evaluated in conformity
with ISO 11654

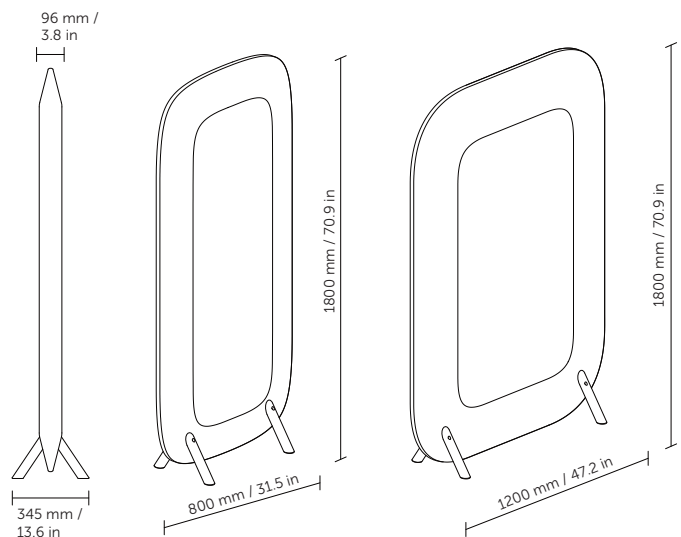

All intellectual property rights („Rights“), whether registered or not, relating to any content, texts, photographs, images, logos, instructions, designs, technical solutions, etc. („Content“) are the property of SilentLab s.r.o. („Owner“) and any interference with these Rights to any Content or part thereof without the prior express and written consent of the Owner is not permitted.

Any use of the Content not expressly authorized in writing in advance, with the exception of internal and non-commercial use of the unmodified Content for the purposes of the customer's own order, is considered an infringement of the Owner's Rights. In particular (not exclusively), any reproduction, change, addition, merger or other modification of the Content is prohibited without the prior express written consent of the Owner.

SILENT LAB

The final product configuration may differ from the versions shown in the photographs.
SilentLab and its logo are registered trademarks of SilentLab s.r.o.

version 2024.1